

INSTRUCTION MANUAL

DC-40
Dust Collector (240V)
700 CFM



W407

IMPORTANT SAFETY INSTRUCTIONS

When using your Dust Collection System, follow basic safety precautions including the following.

WARNING: To reduce the risk of fire, electric shock, or injury:

- Read and understand this owner's manual and all labels on the Dust Collection System before operating. Use only as described in this manual. To avoid personal injury or damage to Dust Collection System, use only recommended accessories.

Sparks inside the electrical parts, can ignite flammable vapors or dust. To avoid fire or explosion:

- Do not vacuum, or use this Dust Collection System near flammable or combustible liquids, gases, gasoline or other fuels, lighter fluid, cleaners, oil-based paints, natural gas, hydrogen, or explosive dusts like coal dust, magnesium dust, grain dust, or gun powder.
- Do not vacuum anything that is burning or smoking, such as cigarettes, matches, or hot ashes.
- To avoid health hazards from vapors or dusts, do not vacuum toxic materials.
- Do not use or store near hazardous materials.
- Do not use outdoors or on wet surfaces.
- Put unit on a stable, level surface.
- Route vacuum hose and electric cord out of traffic areas.
- Do not allow to be used as a toy. Close attention is necessary when used by or near children.
- Do not leave appliance plugged in. Unplug from outlet when not in use and before servicing.

- To avoid injury from accidental starting, unplug power cord before changing or cleaning filter/dust bag or chip bag.
- Do not use without filter/dust bag and/or chip bag in place.
- Do not unplug by pulling on cord. To unplug, grasp the plug, not the cord.
- Turn off controls before unplugging.
- Do not use with damaged cord, plug or other parts. If your Dust Collection System is not working as it should, has missing parts, has been dropped, damaged, left outdoors, or dropped into water, return it to Service Center.
- Do not pull or carry by cord, use cord as handle, close a door on cord, or pull cord around sharp edges or corners. Do not run Dust Collection System over cord. Keep cord away from heated surfaces.
- Do not handle plug of the Dust Collection System with wet hands.
- Do not put any object into ventilation openings. Do not vacuum with any ventilation openings blocked; keep free of dust, lint, hair or anything that may reduce air flow.
- Keep hair, loose clothing, fingers, and all parts of body away from openings and moving parts.
- Extension cords in poor condition or that are too small can pose fire and shock hazards. When using an extension cord, be sure it is in good condition. See "Extension Cords" in the "Operation" section for proper wire sizes.
- Connect to properly grounded outlet only. (See "Grounding Instructions" on page 14.)

SAVE THESE INSTRUCTIONS



⚠ CAUTION: If using this Dust Collection System to help keep airborne wood dust in heavy usage within acceptable limits, you must regularly monitor airborne dust and maintain Dust Collection System to avoid exceeding dust limits. Each application is unique. Your maintenance schedule must, therefore, be tailored to your specific use of this Dust Collection System.

Safety is a combination of common sense, staying alert and knowing how your Dust Collection System works.

BEFORE USING THE DUST COLLECTION SYSTEM:

⚠ WARNING: TO AVOID MISTAKES THAT COULD RESULT IN SERIOUS, PERMANENT INJURY, DO NOT CONNECT POWER CORD UNTIL THE FOLLOWING STEPS HAVE BEEN SATISFACTORILY COMPLETED:

1. Assembly, mounting and alignment.
2. Learn the function and proper use of the ON-OFF switch.
3. Read and understand all safety instructions and operating procedures throughout the manual.
4. Read the following labels which appear on the top and bottom of filtration housing and sides of motor.

⚠ WARNING	
	Metal shavings or dust can set sawdust on fire. Collect wood materials only. Do not collect metal shavings or dust. See manual for details.
	Risk of electrical shock. Use indoors in dry area. Do not use outdoors or on wet surfaces.
	Sparks can ignite vapors from flammable products. Do not use around flammable products.
If connected to a circuit protected by fuses, use time delay fuses with this appliance.	

	⚠ WARNING
Hazardous moving parts inside Unplug before removing inlet guard. Attach inlet guard before plugging in.	

BEFORE EACH USE:

1. Inspect your Dust Collection System. If any parts are missing, bent, or fail in any way, or any electrical components do not work properly, turn off the Dust Collection System, remove switch key, and remove power supply cord from power supply. Replace damaged, missing or failed parts before using the Dust Collection System again.
2. Plan your work to protect your eyes, hands, face, ears and body



A. WEAR SAFETY GOGGLES, FORESIGHT IS BETTER THAN NO SIGHT. Wear safety goggles, not glasses, that comply with ANSI Z87.1 (shown on label). Operating any power tool can result in foreign objects being thrown into the eyes which can result in permanent eye damage. Safety goggles are available at Sears retail catalog stores. Use of glasses or goggles not in compliance with ANSI Z87.1 could result in severe injury from breakage of the eye protection.

B. When cleaning collection bags, wear a dust mask.

GENERAL SAFETY INSTRUCTIONS FOR POWER TOOLS

1. **KNOW YOUR TOOL**
Read and understand owner's manual and labels affixed to the tool. Learn its application and limitations as well as its specific potential hazards peculiar to this tool.
2. **GROUND THE TOOL**
This tool is equipped with an approved 3-conductor cord and a 3-prong grounding type plug to fit the proper grounding type receptacle. The green / yellow conductor in the cord is the grounding wire. Never connect the green / yellow wire to a live terminal.
3. **KEEP GUARDS IN PLACE**
– in working order, and in proper adjustment and alignment.
4. **REMOVE ADJUSTING KEYS AND WRENCHES**
Form habit of checking to see that keys and adjusting wrenches are removed from tool before turning it on.
5. **KEEP WORK AREA CLEAN**
Cluttered areas and benches invite accidents. Floor must not be slippery due to wax or sawdust.
6. **AVOID DANGEROUS ENVIRONMENT**
Don't use power tools in damp or wet locations or expose them to rain. Keep work area well lighted. Provide adequate surrounding work space.
7. **KEEP CHILDREN AWAY**
All visitors should be kept a safe distance from work area.
8. **MAKE WORKSHOP CHILD-PROOF**
– with padlocks, master switches, or by removing starter keys.
9. **USE PROPER SPEED**
This tool will do the job better and safer when operated at the proper speed.
10. **USE RIGHT TOOL**
Don't force tool or attachment to do a job for which it was not designed.
11. **WEAR PROPER APPAREL**
Do not wear loose clothing, gloves, neckties or jewelry (rings, wristwatches) to get caught in moving parts. Non-slip footwear is recommended. Wear protective hair covering to contain long hair. Roll long sleeves above the elbow.
12. **USE SAFETY GOGGLES (Head Protection)**
Wear safety goggles (must comply with ANSI Z87.1) at all times. Everyday eyeglasses only have impact resistant lenses, they are NOT safety glasses. Also, use face or dust mask if cutting operation is dusty, and ear protectors (plugs or muffs) during extended periods of operation.
13. **DON'T OVERREACH**
Keep proper footing and balance at all times.
14. **MAINTAIN TOOLS WITH CARE**
Keep tools sharp and clean for best and safest performance. Follow instructions for lubricating and changing accessories.
15. **DISCONNECT TOOLS**
Before servicing, when changing accessories or attachments.
16. **AVOID ACCIDENTAL STARTING**
Make sure switch is in "OFF" position before plugging in.
17. **USE RECOMMENDED ACCESSORIES**
Consult the owner's manual for recommended accessories. Follow the instructions that accompany the accessories. The use of improper accessories may cause hazards.
18. **NEVER STAND ON TOOL**
Serious injury could occur if the tool tips over. Do not store materials such that it is necessary to stand on the tool to reach them.
19. **CHECK DAMAGED PARTS.**
Before further use of the tool, a guard or other part that is damaged should be carefully checked to ensure that it will operate properly and perform its intended function. Check for alignment of moving parts, binding or moving parts, breakage of parts, mounting, and any other conditions that may affect its operation. A guard or other part that is damaged should be properly repaired or replaced.
20. **NEVER LEAVE MACHINE RUNNING UNATTENDED**
Turn power "OFF". Don't leave Dust Collection System until it comes to a complete stop.

introduction

This Dust Collection System is specifically designed to capture sawdust and wood chips at the source. The fine dust is filtered by the upper bag while heavy particles settle in the lower bag for easy removal. Do not use as a vacuum.

CAUTION: The blower housing contains a high speed fan blade that can amputate fingers, grab loose clothing and neckties, or propel dust at high velocities. **DO NOT OPERATE WITHOUT ALL PARTS IN PLACE.**

Do not attempt to clean, remove dust bags or service unit while in operation. Disconnect from power source.

This Dust Collection System is intended for either commercial or household use.

IMPORTANT NOTE Please Read Carefully

Static Shocks Are Common - in dry areas or when the relative humidity of the air is low. To reduce the fre-

quency of static shocks in your home, the best remedy is to add moisture to the air with a console or installed humidifier.

The safety information in this manual is highlighted by the following safety alert symbol.



The following signal words are used to indicate the level of risk.

DANGER: Means that if the safety information is not followed, someone **will** be seriously injured or killed.

WARNING: Means that if the safety information is not followed, someone **could** be seriously injured or killed.

CAUTION: Means that if the safety information is not followed, someone **may** be injured.

TABLE OF CONTENTS

ITEM	PAGE
WARRANTY INFORMATION	2
IMPORTANT SAFETY INSTRUCTIONS	2
GENERAL SAFETY INSTRUCTIONS FOR POWER TOOLS	4
INTRODUCTION	5
Unpacking and Checking Carton Contents	6
ASSEMBLY	7
Mounting Front Pivoting Casters	7
Mounting Rear Fixed Casters	7
Mounting Inlet Guard	7
Mounting Support Legs	8
Mounting Leg Bracket	8
Mounting Inlet Bracket	9
Mounting Base Plate	9
Mounting Filter/Dust Bag Holder	10
Mounting Handle to Filtration Housing	10
Chip Bag Assembly	11

ITEM	PAGE
Filter/Dust Bag Assembly	11
OPERATION	12
Attaching Accessories to Inlet Guard	12
Connecting Dust Collection System to Power Source	12
On/Off Switch	13
Moving Dust Collection System	13
Power Supply	14
Grounding Instructions	14
Extension Cords	14
MAINTENANCE	15
Chip Collecting Bag Removal	15
Filter/Dust Bag Removal	15
Motor	16
TROUBLESHOOTING	16
REPAIR PARTS	18

introduction

UNPACKING AND CHECKING CARTON CONTENTS

WARNING: IF ANY PARTS ARE MISSING OR BROKEN, GET THE PROPER PARTS FROM STORE BEFORE ASSEMBLY OR USING THIS DUST COLLECTION SYSTEM.

Remove entire contents of carton. Check each item against the Carton Contents List. Notify your Store immediately if any parts are damaged or missing.

CARTON CONTENTS LIST†

Key	Description	Qty.
A	Filter/Dust Bag	1
B	Filter/Dust Bag Hanger	1
C	Handle	1
D	Filtration Housing	1
E	Inlet Guard	1
F	Right Side Support Leg	1
G	Loose Parts Bag	1
H	Rear Fixed Casters	2
I	Base Plate	1
J	Front Pivoting Casters	2
K	Manual	1
L	Chip Collecting Bag	1
M	Bracket and Inlet Clamp	1
N	Leg Bracket	1
O	Left Side Support Leg	1
P	Adjustable Band Clamp	1
Q	Flexible Hose, 4 Inch	1
R	Adapter	1
S	O-Ring	1

WARNING: PLUGGING THE DUST COLLECTION SYSTEM IN DURING ASSEMBLY CAN RESULT IN ELECTRICAL SHOCK OR YOUR FINGERS, HAND, OR ARM BEING CUT OFF FROM FAN BLADE CONTACT. DO NOT PLUG IN THE COLLECTOR AT ANY TIME DURING ASSEMBLY. THE DUST COLLECTION SYSTEM SHOULD ONLY BE PLUGGED IN WHEN IT IS TO BE USED.

LIST OF PARTS IN LOOSE PARTS BAG†

Key	Description	Qty.
Q	Hex Nut	
	M6 x 1	5
	3/8 - 16	2
R	Lockwasher	
	1/4	9
	5/16	8
S	Hex Screw	
	M6 x 1 - 30	4
	M6 x 1 - 12	6
	M8 x 1.25 - 12	18

Tools Needed (Not included with machine)



Adjustable Wrench



Screwdriver

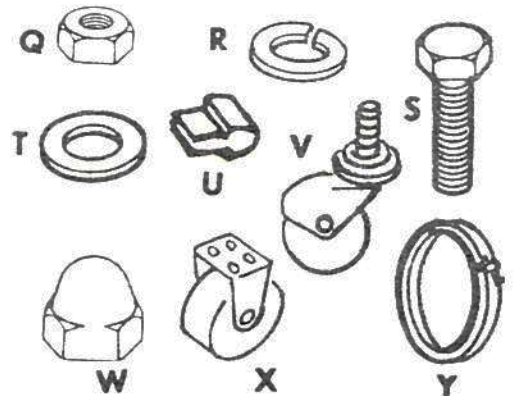
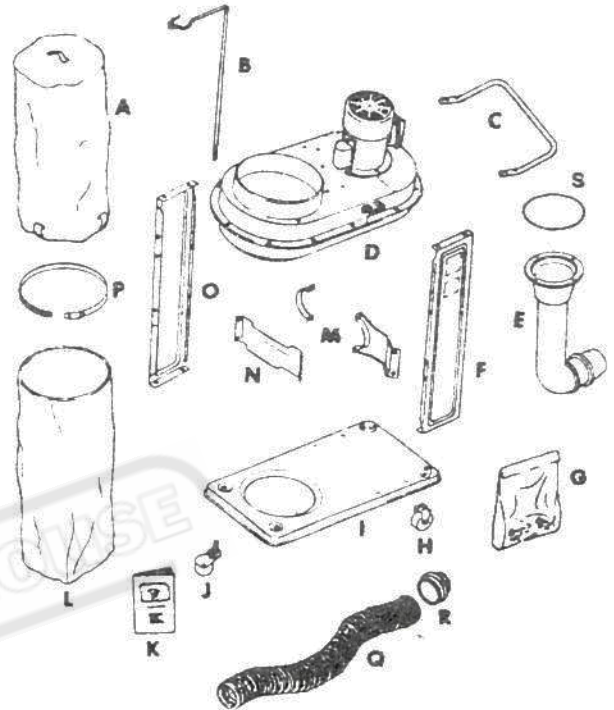

T	Flat Washer	
	1/4 x 1/2	7
	5/16 x 11/16 x 1/16	18
U	Switch Key	1
	Pivoting Caster	2
W	Acorn Nut 3/8 - 16	2
X	Fixed Caster	2
Y	Hose Clamp	2

assembly

MOUNTING FRONT PIVOTING CASTERS

1. Locate the following items from the loose parts bag:

Description	Qty.
A Pivoting Casters	2
B Hex Nuts* (3/8 - 16)	2
C Flat Washers* (3/8 x 3/4)	4
D Acorn Nuts*	2
E Base Plate	1

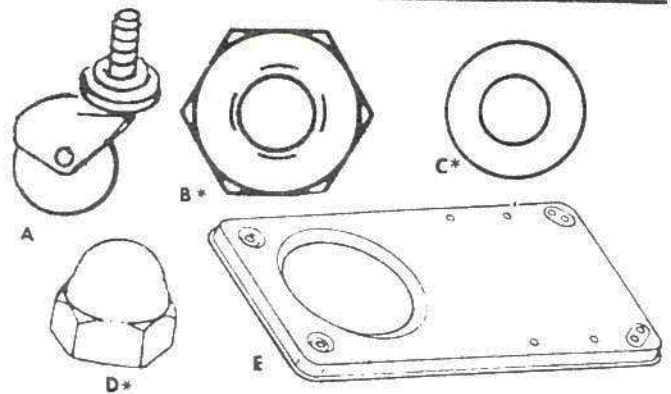

- Screw a hex nut completely on the *Caster bolt*.
- Position flat washer on top of previously installed hex nut and slip the *Caster bolt* through the hole on front of *Base Plate*. Position second flat washer on the bolt.
- Screw the *Acorn Nut* on the bolt securely with an adjustable wrench.
- Tighten the hex nut securely against the base plate.
- Repeat steps 2 - 5 on opposite side.

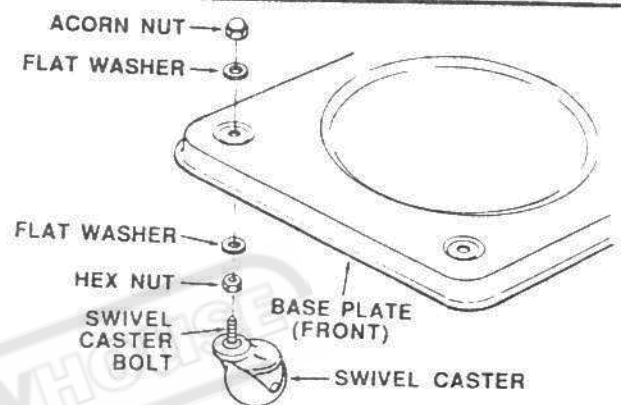

MOUNTING REAR FIXED CASTERS

1. Locate the following items from the loose parts bag:

Description	Qty.
A Fixed Casters	2
B Flat Washers* (1/4 x 1/2)	4
C Lockwashers* (1/4)	4
D Hex Head Screws* (M6 x 1 - 12)	4

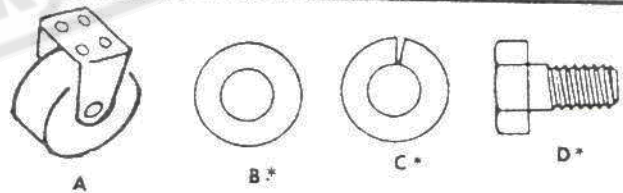

- Position *Fixed Caster* under rear of *Base Plate* so that holes on *Caster bracket* and *Base Plate* line up.
- Install hex screw, lock washer, and flat washer as shown. Tighten securely using an adjustable wrench
- Repeat steps 2 and 3 on opposite side.

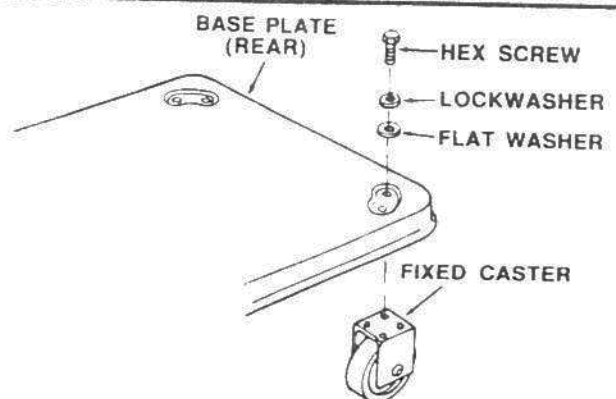

MOUNTING INLET GUARD

1. Locate the following items from the loose parts bag:

Description	Qty.
A Flat Washers* (5/16 x 11/16 x 1/16)	4
B Hex Screws* (M8 x 1.25 - 12)	4
C Lockwashers* (5/16)	4

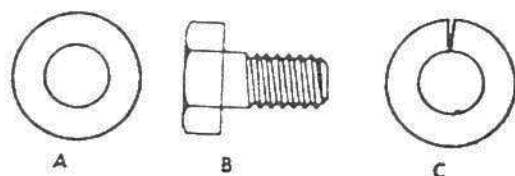

- Locate the *Filtration Housing* and *Inlet Guard*.

assembly

- Carefully turn the *Filtration Housing* upside down so that the *Motor* endbell rests against the floor.
- Support the opposite side of *Filtration Housing* with a block of wood.
 - Place *O-Ring* in relief of *Inlet pipe* (See page 18)
- Position *Inlet Guard* in line with the threaded holes on the base of the *Filtration Housing*.

NOTE: Make sure *Inlet Guard* is pointing to rear of machine.
- Place lockwasher and flat washer on hex screw and insert through the holes of the *Inlet Guard* into the threaded holes of the *Filtration Housing* as shown.
- Complete the process for the other three holes using same method.

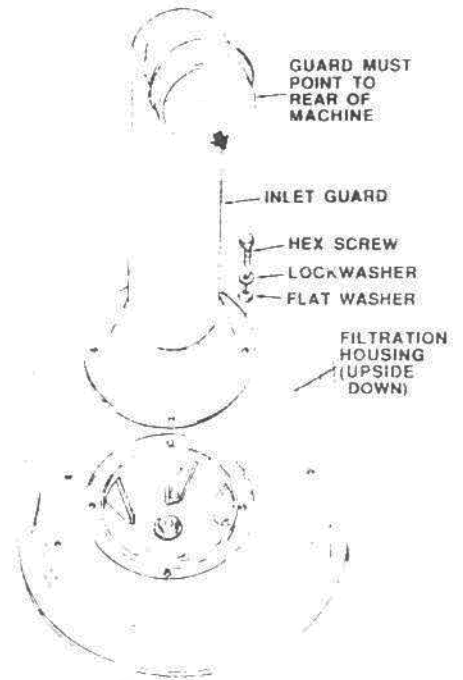

MOUNTING SUPPORT LEGS

- Locate the following items from the loose parts bag:

Description	Qty.
A Flat Washers* (5/16 x 11/16 x 1/16)	4
B Hex Screws *(M8 x 1.25 - 12)	4
C Lockwashers* (5/16)	4

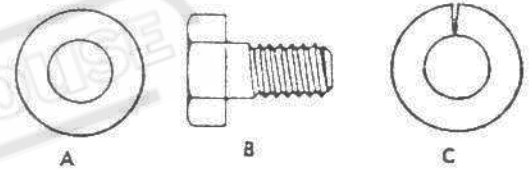

CAUTION: To avoid injury, keep hands away from fan blade.

- Position left *Leg Support* as shown.
- Place lockwasher and flat washer on hex screw and insert through the holes in the *Support Leg* and secure to the threaded holes in the *Filtration Housing* as shown.
- Use same method to attach *Right Support Leg*.
- Secure hex screws with the use of adjustable wrench.

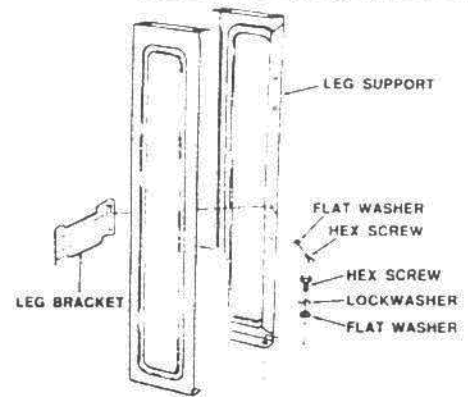

MOUNTING LEG BRACKET

- Locate the following items from the loose parts bag:

Description	Qty.
A Flat Washers* (5/16 x 11/16 x 1/16)	4
B Hex Screws* (M8 x 1.25 - 12)	4
- Insert *Leg Bracket* between the *Support Legs* and slide against the angled flange of the *Leg*.

NOTE: Make sure holes in *Leg Bracket* align with holes on *Leg Support*.
- Place flat washer on hex screw, insert through angled

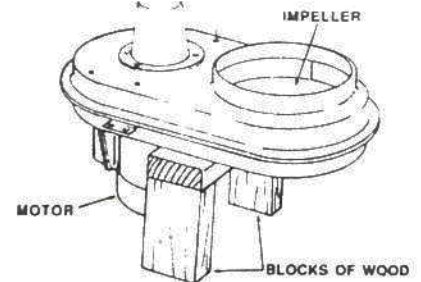

flange of *Leg Support* and attach to threaded hole of *Bracket*.

- Repeat steps 2 and 3 using same process on other three holes.

MOUNTING INLET BRACKET

1. Locate the following items from the loose parts bag:

Description	Qty.
A Flat Washers* (5/16 x 11/16 x 1/16)	2
B Hex Screws* (M8 x 1.25 - 12)	2
C Flat Washers* (1/4 x 1/2)	2
D Hex Screws* (M6 x 1 - 12)	2

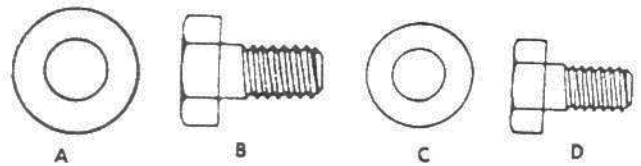

2. Insert *Inlet Bracket* between relief flange of *Inlet Guard* and against inside edge of angle flange on *Support Leg*. Make sure both holes on *Bracket* align with similar holes on *Leg Support*.

3. Place 5/16 flat washer on hex screw, insert through *Leg* hole and attach to threaded hole of *Bracket*.

4. Repeat same process for other hole and secure with use of adjustable wrench.

5. Attach *Fixed Clamp* as shown, by placing flat washer on hex screw, insert hex screw through hole of *Fixed Clamp* and attach to threaded hole of *Inlet Guard Bracket*.

6. Repeat step 5 to attach other screw below *Inlet Guard*.

7. Tighten all screws on *Legs*, *Inlet Guard*, and *Filtration Housing* securely.

CLAMP AND BRACKET MOUNT HERE

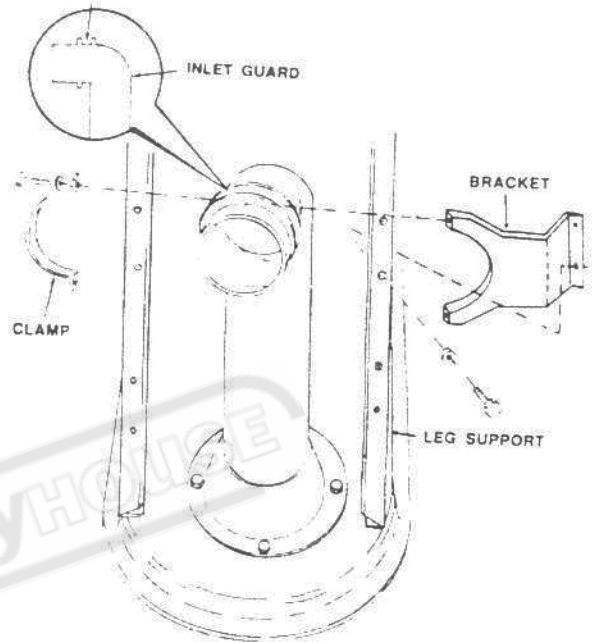

MOUNTING BASE PLATE

1. Locate the following items from the loose parts bag:

Description	Qty.
A Flat Washers* (5/16 x 11/16 x 1/16)	4
B Hex Screws* (M8 x 1.25 - 12)	4

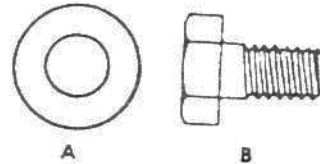

2. Attach *Base Plate* to *Leg Supports* by flipping base upside down, aligning holes on both *Leg Supports*.

3. Place flat washer on hex screw, insert through hole of *Leg* and attach to threaded holes in *Base Plate* as shown.

4. Repeat same process for other three holes and secure with adjustable wrench.

5. With the assistance of another person, carefully flip the *Dust Collection System* right side up.

FIXED CASTERS BASE PLATE SWIVEL CASTERS

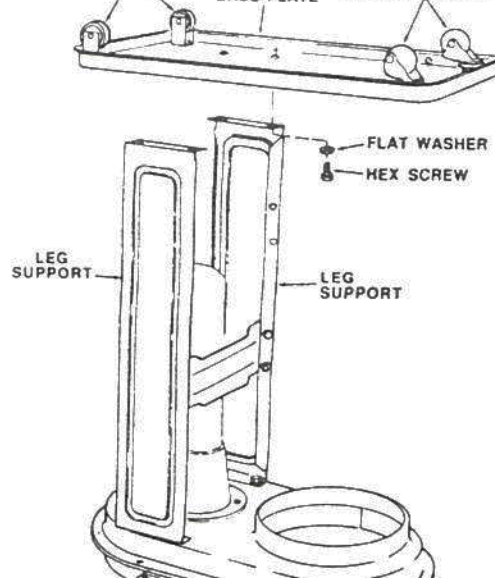

assembly

MOUNTING FILTER/DUST BAG HOLDER TO FILTRATION HOUSING

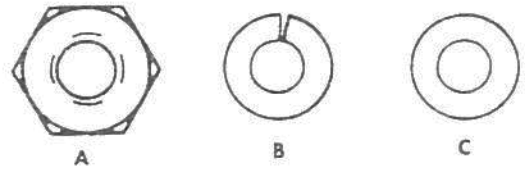

1. Locate the following items from the loose parts bag:

Description	Qty.
A Hex Nut* (M6 x 1)	1
B Lockwasher* (1/4)	1
C Flat Washer* (1/4 x 1/2).....	1

2. Attach hex nut to threaded portion of *Filter/Dust Bag Holder* and place lockwasher and flat washer on nut as shown.
3. Insert *Filter/Dust Bag Holder* into threaded hole of *Filtration Housing* as shown.
4. Turn *Filter/Dust Bag Holder* rod clockwise until nut is secured to *Filtration Housing*.
5. Secure *Filter/Dust Bag Holder* in place with adjustable wrench.

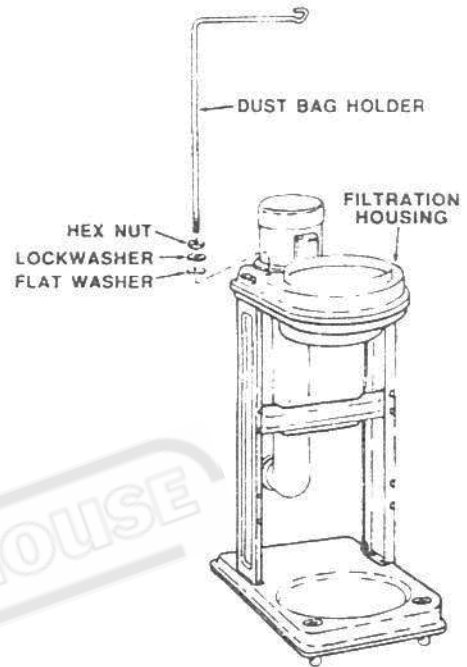

MOUNTING HANDLE TO FILTRATION HOUSING

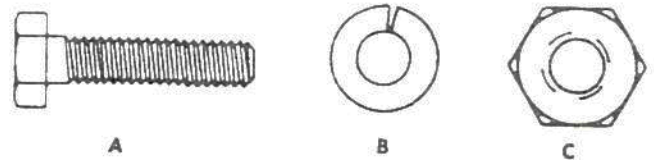

1. Locate the following items from the loose parts bag:

Description	Qty.
A Hex Screws* (M6 x 1-30).....	4
B Lockwashers* (1/4" dia.).....	4
C Hex Nuts* (M6 x 1)	4

2. Attach the ends of the *Handle* to the *Relief Flanges* on the side of *Filtration Housing* as shown.
3. Insert hex screw through the *Handle* and *Flange*.
4. Attach the lockwasher and the hex nut to the screw and tighten.
5. Repeat process for all four holes and secure with adjustable wrench.

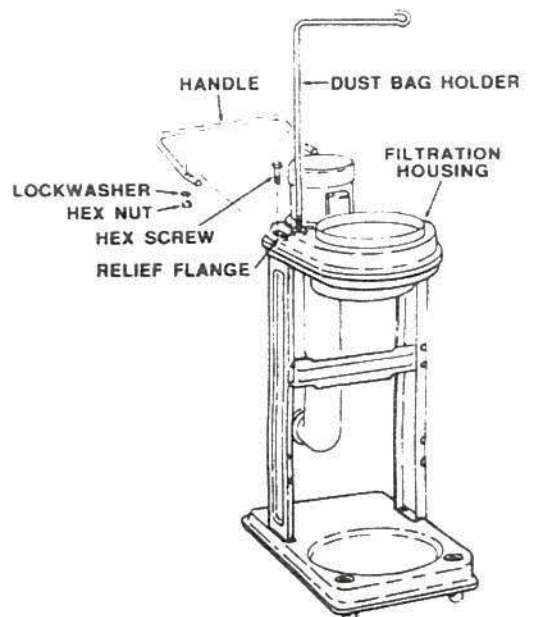

CHIP BAG ASSEMBLY - LOWER FILTRATION HOUSING

1. Insert lower *Chip Bag* by tilting the *Metal Reinforced Band* at an angle and position it through the hole in the lower *Filtration Housing*.
2. Tuck one side of the *Band* under the *Sawdust Shoot Extension*.
3. Allow the opposite side to rest on the ridge of the opening.
4. Tug on the *Chip Bag* to insure proper seating.

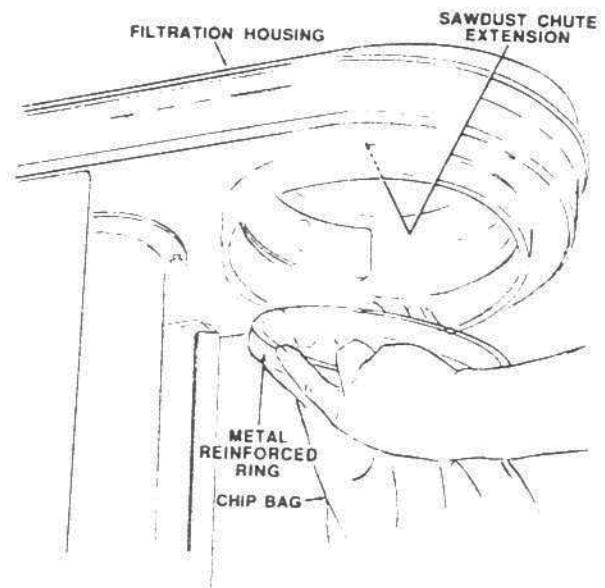

UPPER FILTER/DUST BAG ASSEMBLY

1. Disconnect the *Adjustable Band Clamp* and insert the end through the loops provided at the opening of the *Filter/Dust Bag*.
2. Invert the *Filter/Dust Bag* and slip the open end of the *Bag* over the 1" Relief on the top opening of the *Filtration Housing*.
3. Secure the *Bag* by adjusting the rectangular bar to the fourth set of hooks.
4. Pull the lever tight until it sets itself.

⚠ CAUTION: Make sure the opening of the bag is tight against the relief so dust will not escape.

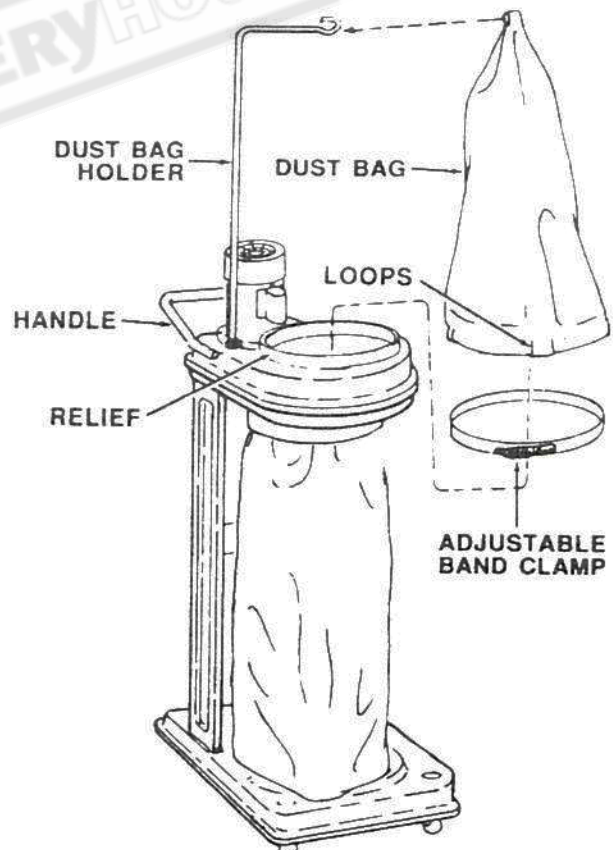

operation

This Dust Collection System is designed to be connected directly to the woodworking machines. Please, use only the parts provided for maximum efficiency.

4" Diameter x 60" Hose. PVC Vulcanized rubber with wire reinforcement and 2 - 4" clamps.

4"/2-1/2" Diameter Adaptor. This connector allows direct hookup to many machines including Band-saws, Belt and Disk Sanders, and Radial Saw Sawdust Collector.

⚠ WARNING: To avoid fire or explosion caused by the Igniting of vapors or dust due to the arcing of

electrical parts, do not operate this Dust Collector System in areas with flammable vapors such as lighter fluid, cleaners, oil-base paints, gasoline alcohol or explosive dust such as coal, magnesium grain or gun powder in the air. Do not vacuum explosive dust, flammable or combustible liquids or hot ashes. To avoid health hazards from vapors or dusts, do not use near toxic materials. To avoid electrical shock, do not expose to rain. Store indoors. Unplug power cord before changing, cleaning, or emptying the filter/dust bag or chip bag.

ATTACHING ACCESSORIES TO INLET GUARD

4" Diameter Hose/Clamp Assembly and Adaptor

1. Open *Clamp* and insert *Hose* as shown, by slipping *Clamp* over *Hose*. Attach to *Inlet Guard* and tighten *Clamp* with a straight blade screwdriver. Use this same process to connect *Adaptor*. Tighten both *Clamps* securely to increase air velocity and reduce leakage. The *Adaptor* will permit easy disconnect.

⚠ CAUTION: To avoid fire, use only the hose and adaptor designed for this unit. The adapter is designed to fit only to the hose. Do not attach it directly to any other inlet opening.

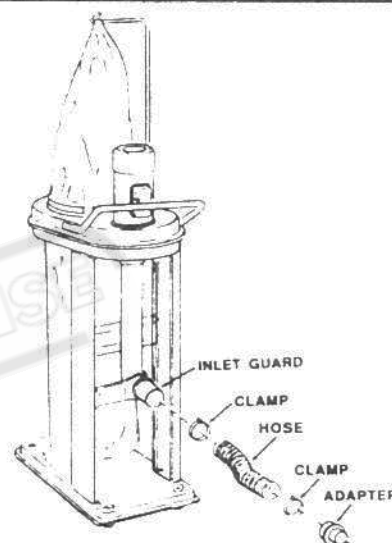

CONNECTING DUST COLLECTION SYSTEM TO POWER SOURCE

⚠ CAUTION: If connected to a circuit protected by fuses, use time delay fuses with this appliance.

1. Prior to connecting your Dust Collection System to any power source, be sure your bags are installed properly. This will remove any possibility of dust flying in your face.
2. Make sure the voltage of motor and motor rating agree with the electrical system it is to be connected to.
3. Too many machines on one circuit will blow fuses. Be careful not to overload circuit.

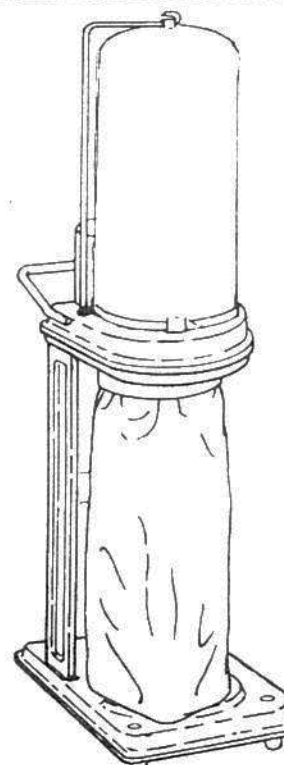

ON / OFF SWITCH

On the rear of the *Motor Housing* above the *Handle*, is the *Switch Box*. The ON/OFF Switch has the ability to be turned "ON" when the *Red Key* is properly installed. Switch to the "ON" position by moving the switch upward. Turn the switch "OFF" by moving downward. Remove the *Key* from the switch whenever the saw is turned "OFF" and keep it out of the reach of children.

⚠ WARNING: THE DUST COLLECTION SYSTEM CAN START ACCIDENTALLY OR BE USED BY CHILDREN OR OTHERS WHEN THE KEY IS LEFT IN THE SWITCH. ALWAYS REMOVE KEY WHEN THE DUST COLLECTION SYSTEM IS 'OFF', AND KEEP IT OUT OF THE REACH OF CHILDREN.

⚠ WARNING: THE DUST COLLECTION SYSTEM WILL START IMMEDIATELY WHEN THE POWER COMES BACK ON AFTER A BLACKOUT IF THE KEY IS LEFT 'ON' IN THE SWITCH. ALWAYS TURN THE SWITCH 'OFF' AND REMOVE THE KEY.

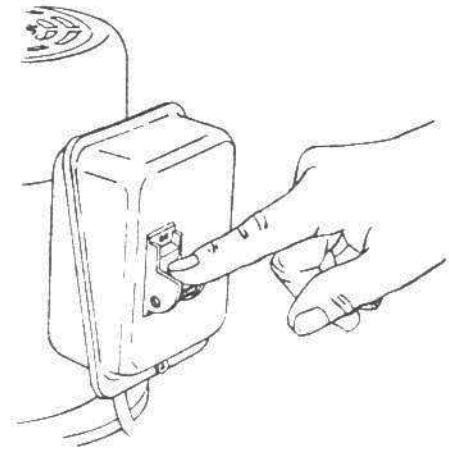

Turning Switch "OFF"

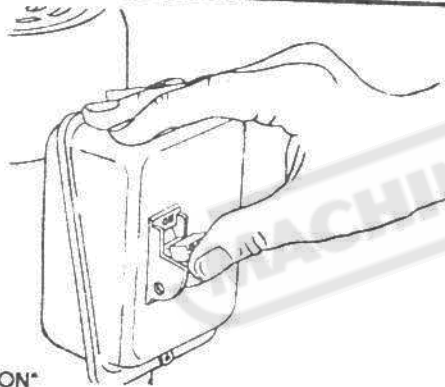

Turning Switch "ON"

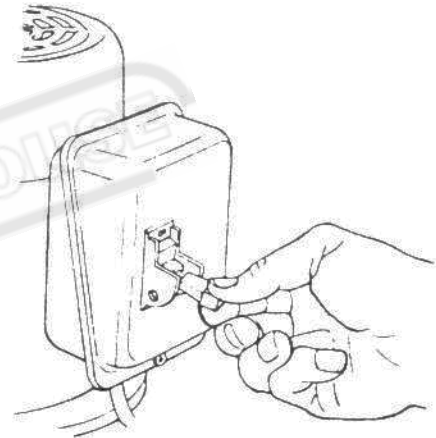

Removing Switch Key

NOTICE : The type of Switch on your dust collector might be different to the above ON/OFF switch for your country.

operation

POWER SUPPLY

⚠ WARNING: ALWAYS MAKE SURE THE VOLTAGE OF MOTOR AND MOTOR RATING AGREE WITH THE ELECTRICAL SYSTEM WHICH IS TO BE CONNECTED TO FOR YOUR DUST COLLECTOR OPERATION. CONNECT TO THE RIGHT ELECTRICAL SYSTEM AND USE TIME DELAY FUSE OR CIRCUIT BREAKER. FAILURE TO CONNECT IN THIS WAY CAN RESULT IN INJURY FROM SHOCK OR FIRE.

Your Dust Collection System must be properly grounded. Not all outlets are properly grounded. If you are not sure that your outlet is properly grounded, have it checked by a qualified electrician.

⚠ WARNING: IF NOT PROPERLY GROUNDED, THIS DUST COLLECTION SYSTEM CAN CAUSE ELECTRICAL SHOCK, PARTICULARLY WHEN USED IN DAMP LOCATIONS.

⚠ WARNING: TO AVOID SHOCK OR FIRE, IF POWER CORD IS WORN, CUT, OR DAMAGED IN ANY WAY, HAVE IT REPLACED IMMEDIATELY.

GROUNDING INSTRUCTIONS

This appliance must be grounded. If it should malfunction or breakdown, grounding provides a path of least resistance for electric current to reduce the risk of electric shock. This appliance is equipped with a cord having an equipment-grounding conductor and grounding plug. The plug must be plugged into an appropriate outlet that is properly installed and grounded in accordance with all local codes and ordinances.

⚠ WARNING: TO MAINTAIN PROPER DUST COLLECTION SYSTEM GROUNDING, WHENEVER THE OUTLET YOU ARE PLANNING TO USE FOR THIS POWER TOOL IS OF THE TWO PRONG TYPE, DO NOT REMOVE OR ALTER THE GROUNDING PRONG IN ANY MANNER.

EXTENSION CORDS (Example for Reference Only)

The use of any extension cord will cause some loss of power. Use the following table to determine the minimum wire size (A.W.G.) extension cord. Use only 3-wire extension cords which have 3-prong grounding type plugs and 3-pole receptacles which accept the tool's plug.

For circuits that are farther away from electrical circuit

This appliance is for use on a nominal 120-volt circuit and has a grounded plug that looks like the plug illustrated below. A temporary adapter may be used to connect this plug to a 2-pole receptacle, as shown below, if a properly grounded outlet is not available. The temporary adapter should be used only until a properly grounded outlet can be installed by a qualified electrician. The green colored rigid ear, lug, or the like, extending from the adapter must be connected to a permanent ground such as a properly grounded outlet box cover. Whenever the adapter is used, it must be held in place by a metal screw.

⚠ WARNING: IMPROPER CONNECTION OF THE EQUIPMENT GROUNDING CONDUCTOR CAN RESULT IN A RISK OF ELECTRIC SHOCK. CHECK WITH A QUALIFIED ELECTRICIAN OR SERVICE PERSON IF YOU ARE IN DOUBT AS TO WHETHER THE OUTLET IS PROPERLY GROUNDED. DO NOT MODIFY THE PLUG PROVIDED WITH THE APPLIANCE IF IT WILL NOT FIT THE OUTLET, HAVE A PROPER OUTLET INSTALLED BY A QUALIFIED ELECTRICIAN.

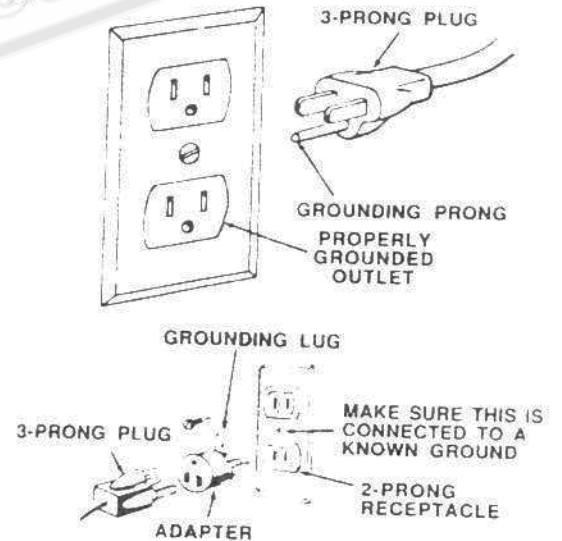

⚠ WARNING: THE ADAPTER ILLUSTRATED IS FOR USE ONLY IF YOU ALREADY HAVE A PROPERLY GROUNDED 2-PRONG RECEPTACLE.

NOTE: IN CANADA, THE USE OF A TEMPORARY ADAPTOR IS NOT PERMITTED BY THE CANADIAN ELECTRICAL CODE.

box, the wire size must be increased proportionately in order to deliver ample voltage to the saw motor.

Length of Conductor	Wire Sizes Required
	(American Wire Gage 120V Lines)
0 - 25 feet	No. 16
26 - 50 feet	No. 14
51 - 100 feet	No. 12

maintenance

⚠ WARNING: FOR YOUR OWN SAFETY, TURN SWITCH "OFF" AND REMOVE PLUG FROM POWER SOURCE OUTLET BEFORE MAINTAINING YOUR DUST COLLECTION SYSTEM.

⚠ WARNING: TO AVOID INJURY FROM ELECTRIC SHOCK OR SUDDENLY STARTING UNIT, ALWAYS REMOVE SWITCH KEY AND KEEP UNPLUGGED WHILE UNIT IS DISASSEMBLED IN ANY WAY. ALWAYS REASSEMBLE WITH RECOMMENDED PARTS BEFORE PLUGGING UNIT IN.

CHIP COLLECTING BAG REMOVAL

1. Push *Band* up and slide opposite edge to the middle opening.
2. Lower *Band* carefully through opening as shown. Deposit chips in appropriate metal container.

⚠ CAUTION: Wear Safety goggles ANSI Z87.1 to protect your eyes prior to commencing operation.

3. Reconnect the *Chip Collecting Bag* by sliding the *Band* through the hole and slide the opposite side under *Dust Shoot Extension*. Seat as shown.

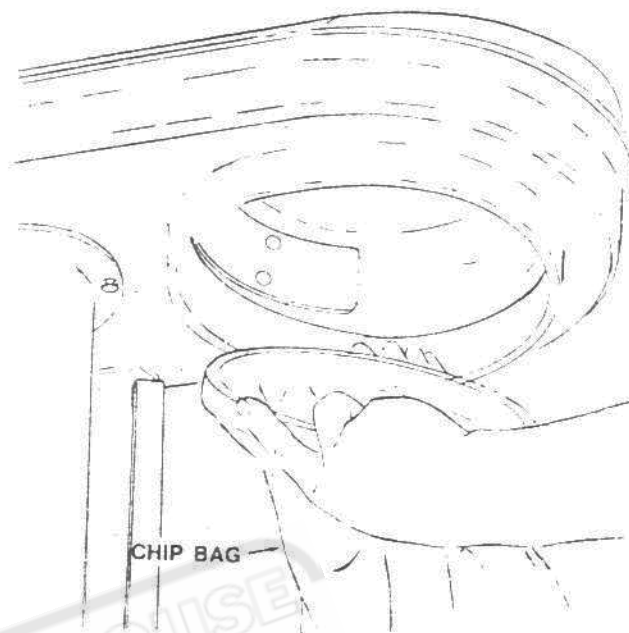

FILTER/DUST BAG REMOVAL

⚠ CAUTION: If using this Dust Collection System to help keep airborne wood dust in heavy usage within acceptable limits, you must regularly monitor airborne dust and maintain Dust Collection System to avoid exceeding dust limits. Each application is unique. Your maintenance schedule must, therefore, be tailored to your specific use of this Dust Collection System.

1. Shake the *Filter/Dust Bag* so the fine dust falls into lower *Chip Collecting Bag*.
2. Disconnect the *Adjustable Band Clamp* by releasing the *Spring Lever Clamp*.
3. Remove the *Filter/Dust Bag* and deposit all fine dust in an appropriate metal container.
4. Reconnect the *Bag* carefully so the *Clamp* wraps around the *Bag* on all sides. Adjust the lever to the fourth hook and fasten securely.
5. Slip loop over hook on *Filter/Dust Bag Holder*.

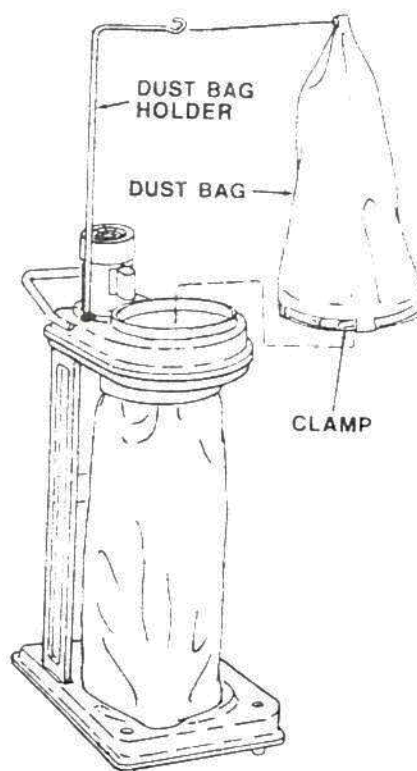

maintenance

MOTOR

Excessive dust in motor could cause excessive heat in motor.

Every effort should be made to prevent foreign material from entering the motor. When operated under conditions likely to permit accumulations of dust, dirt, or waste within the motor, a visual inspection should be made at frequent intervals. Accumulations of dry dust can usually be blown out successfully.

NOTE: Motors used on wood-working tools are particularly susceptible to the accumulation of sawdust and wood chips and should be blown out or "vacuumed" frequently to prevent interference with normal motor ventilation.

To remove dust, blow off motor with a low pressure air hose.

CAUTION: To avoid eye injury or adverse reaction to dust, high air pressure should not be used especially in poorly ventilated areas.

The operator performing this cleaning function should wear safety goggles and filter mask.

Do not use unit if power cord becomes worn or frayed.

NOTE: The speed of this motor cannot be regulated or changed.

troubleshooting

MOTOR

PROBLEM	PROBABLE CAUSE	REMEDY SUGGESTED
Motor will not run.	<ol style="list-style-type: none"> 1. Defective cord, plug, switch and/or motor. 2. Blown fuse. 	<ol style="list-style-type: none"> 1. Consult Service. Any attempt to repair this motor may create a hazard unless repair is done by a qualified service technician. Repair service is available at your nearest service center. 2. Check for blown fuses and replace with fuse of proper capacity.
Excessive sawdust in air.	<ol style="list-style-type: none"> 1. Loose connectors 2. Filter/dust bag and/or chip collection bag releasing sawdust. 	<ol style="list-style-type: none"> 1. Tighten connections. 2. a. Sawdust trapped between clamp bag and housing. b. Lower bag is hung up on sawdust shoot extension. Reposition chip bag properly. See "Maintenance - Chip Bag".
Excessive impeller noise.	<ol style="list-style-type: none"> 1. Picked up large wood chips or debris. 2. Loose impeller. 3. Rubbing impeller. 	<ol style="list-style-type: none"> 1. Do not pick up metal or ferrous materials. Stop the machine and the material will fall to the bottom of inlet tube. 2. Unplug unit prior to disassembly. Hazardous moving parts inside. Attach inlet guard before plugging in. Use a piece of wood to free impeller. 3. Consult Service to repair loose or rubbing impeller. A repair to the housing may create a hazard unless it is done by a qualified service technician. Repair service is available at your nearest service center.

PROBLEM	PROBABLE CAUSE	REMEDY SUGGESTED
Excessive noise.	1. Motor	1. Have motor checked by qualified service technician. Repair service is available at your nearest service center.
Motor fails to develop full power. NOTE: LOW VOLTAGE: (Power output of motor decreases rapidly with decrease in voltage at motor terminals. For example, a reduction of 19% in maximum power output of which the motor is capable and a reduction of 20% in voltage causes a reduction of 36% in maximum power output.)	1. Circuit overloaded with lights, appliances and other motors. 2. Undersize extension cord or extension cord too long. 3. General overloading of power company facilities.	1. Do not use other appliances or motors on same circuit when using the Dust Collection System. 2. Increase the wire sizes on extension cords, or reduce length of extension cords. See "Motor Specifications and Electrical Requirements" section. 3. Request a power check from the power company.
Motor starts slowly or fails to come up to full speed.	1. Low voltage. 2. Windings burned out or open. 3. Starting switch will not operate. (Switch contacts working properly.) Capacitor is bad.	1. Request voltage check from the power company. 2. Have motor repaired or replaced by a qualified service technician. 3. Have capacitor replaced by a qualified service technician.
Motor overheats	1. Motor overloaded. 2. Improper cooling. (Air circulation restricted through motor due to sawdust, accumulating inside of motor.)	1. Clean out sawdust to provide normal air circulation through motor. See "Maintenance" section.
Motor stalls (resulting in blown fuses or tripped circuit breakers).	1. Voltage too low to permit motor to reach operating speed. 2. Fuses or circuit breakers do not have sufficient capacity.	1. Request voltage check from the power company. 2. Install proper size fuses or circuit breakers.
Frequent opening of fuses or circuit breakers.	1. Motor overloaded. 2. Fuses or circuit breakers do not have sufficient capacity.	1. Install proper size fuses or circuit breakers.

NOTE: Motors used on wood-working tools are particularly susceptible to the accumulation of sawdust and wood chips and should be blown out or "vacuumed" frequently to prevent interference with normal motor ventilation and proper operation of the centrifugally-operated starting switch.

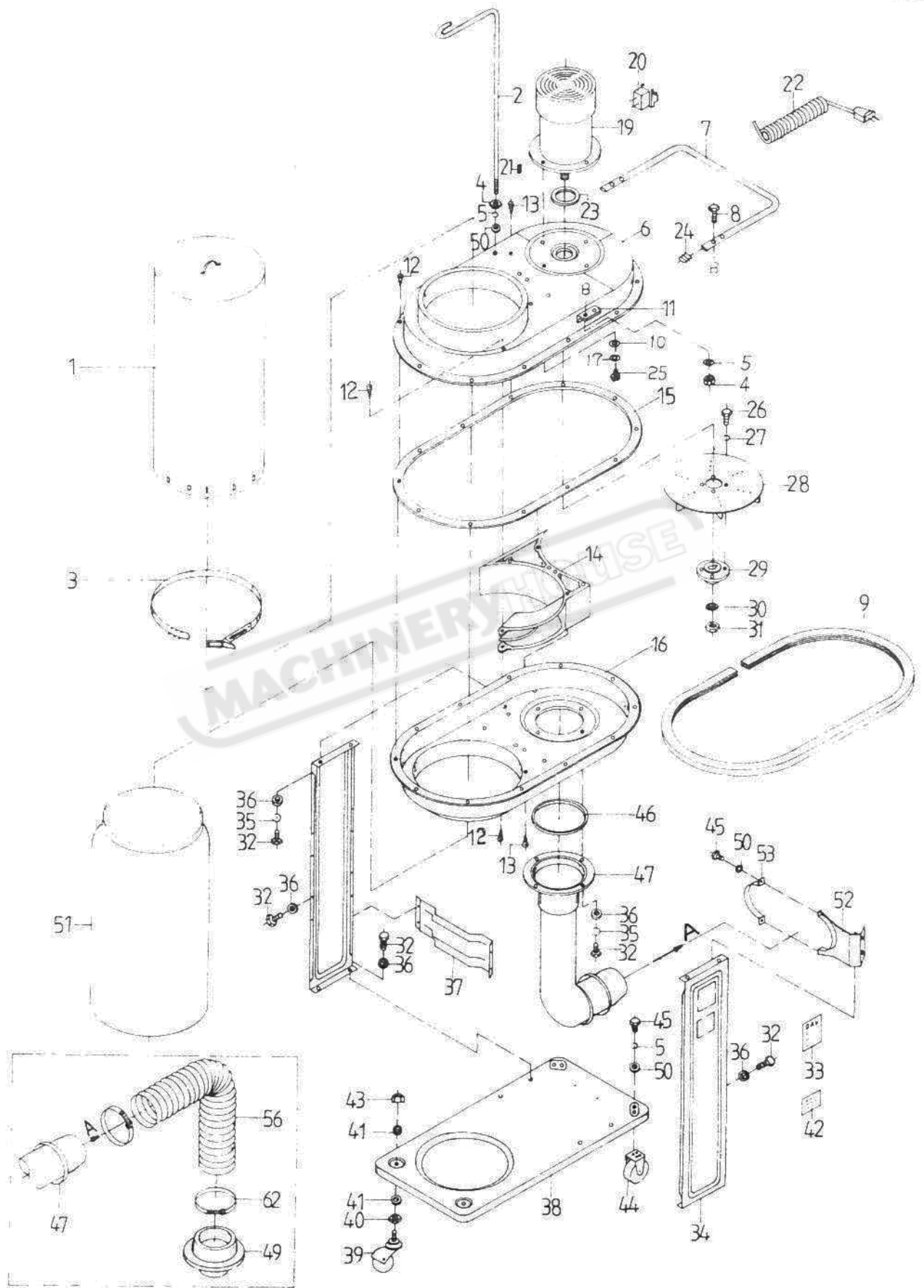

PARTS LIST

Item No.	Part No.	Description
1	423001	Filter Bag
2	423002	Hanger
3	423003	Retainer Strap
▲ 4	991111	Nut M6×1
▲ 5	991921	Spring Washer M6
6	423006	Upper Housing
7	423007	Handle
▲ 8	990116	Hex. Head Bolt M6×1×30
9	423009	Rubber Edge Sleeve
10	991717	F. Washer M6×φ13
11	423011	Handle Supporting Plate
12	990805	Self Tapping Bolt M4×0.7×10
13	990811	Self Tapping Bolt M3.5×0.6×12
14	423914	Inner Isolator
15	423015	Gasket
16	423016	Lower Housing
17	991921	Spring Washer M6
19	423019	Motor
20	994532	Switch
21	992013	Key □ 5×25
22	999910	Power Cord
23	423023	Motor Gasket
24	423024	Plug
25	990112	Hex. Head Bolt M6×1×12
26	990131	Hex. Head Bolt M8×1.25×16
27	991931	Spring Washer M8
28	421018	Impeller

Item No.	Part No.	Description
29	420007	Bushing
30	991851	F. Washer M16×φ40
31	991373	Nut M16×1.5
▲ 32	990130	Hex. Head Bolt M8×1.25×12
33	999912	Nameplate
34	423034	Supporting Plate
▲ 35	991931	Spring Washer M8
▲ 36	991743	F. Washer M8×φ18
37	423037	Fixed Plate
38	423038	Base
39	410001	Castor Wheel
▲ 40	991221	Nut 3/8"×16UNC
▲ 41	991751	F. Washer M10×φ20
42	999919	Warning Label
▲ 43	991452	Hex. Head Nut 3/8"×16UNC
44	423044	Fixed Caster
▲ 45	990112	Hex. Head Bolt M6×1×12
46	423946	O-Ring
47	423047	Inlet Cover
49	423910	Reducer
▲ 50	991712	F. Washer M6×φ13
51	423051	Collection Bag
52	423052	Bracket Inlet Support
53	423053	Inlet Support Clamp
56	423908	Pipe Inlet
62	423962	Ring Clamp

▲ Hardware package

SDC - 2041 HE

owners manual

SERVICE

Dust Collection System

HOW TO ORDER
REPAIR PARTS

DUST COLLECTION SYSTEM

WHEN ORDERING REPAIR PARTS, ALWAYS
GIVE THE FOLLOWING INFORMATION:

PART NUMBER PART DESCRIPTION

MODEL NUMBER NAME OF ITEM
Dust Collection
System

All parts listed may be ordered from any Service Center and most stores. If the parts you need are not stocked locally, your order will be electronically transmitted to original maker for handling.